

# Radio Signal Modelers Flying Club



## March 2011 Newsletter

March 7, 2011

The March meeting was called to order at the Strictly RC basement location by President Les Schier at the club's new meeting time at 6 pm. The minutes of the February meeting were read by Secretary Ted Noncek and approved by the club. There were 24 members in attendance.

### Treasurer's Report

Treasurer Terry Gombert presented the Treasurer's report. The club started February with \$1,392 including \$314 in Pay Pal. During the month, dues were collected totaling \$400. Disbursements totaling \$258 were made during February consisting of AMA Charter club dues and the renewal of our incorporation status with the Illinois Secretary of State. As a result, the club's ending cash balance as of February 28, 2011 was \$1,534, including \$150 held in the Pay Pal account. The Treasurer's report was approved by the club.

### Membership Dues

All members are reminded to renew their RSM membership for 2011. Members can pay at the meetings or by renewing on the club's website [radiosignalmodelers.com](http://radiosignalmodelers.com) where you can pay your \$50 annual dues using Pay Pal.

### Committee Reports

Field Maintenance: Chairman Mike Reinhart answered questions as to whether the battery in the tractor was removed before winter. Mike noted that the battery was not removed and that he did not believe we would have trouble with it once the cutting season starts. Additional discussions took place regarding offers to store the tractor this year that were not taken up. Tim Gombert noted that he was in the process of fixing or replacing the shed lock since the hardware store confirmed that the tumblers were in disrepair. A less-secure temporary lock had

to be used in the interim while the lock was being repaired.

Terry Gombert discussed placing a metal mailbox at the field that could be used to store membership forms. The club discussed that other clubs also used clear tubes sometimes used by real estate agents to display property information sheets.

Flight Training Committee: Chairman Don Zeller reported that he continues in the information gathering phase of pulling together a training plan. The club discussed designating our trainers with the special introductory pilot program designation from the AMA trainee. The club authorized the Flight Training Committee to apply for the instructor designation for \$5 for each instructor. This additional designation provides for the ability to train a non-AMA for up to sixty days using the non-member's equipment. It was noted that the club would not intend to train a non-AMA member for that long, but that it would provide an outlet for training a newcomer to the hobby who presents at the field unaware of AMA requirements.

President Les asked Treasurer Terry whether he had ordered instructor patches yet, Terry indicated that he would receive these with other patches from the AMA for officers.

Planning Committee: Chairman Tim Gombert discussed several items he has been working on since the last meeting. Tim noted that the club would like to return to all members displaying either their club or AMA card while flying. He noted that we all need to follow this protocol at the field so that we can enforce AMA-only requirements at the field. With the advent of 2.4GHz transmitters, frequency control is no longer necessary so members have been lax in putting a card up. Tim is working to convert

some of the lesser-used 50MHz slots to slots for 2.4GHz fliers. All club members are required to display their cards when flying.

During the discussion on display of AMA/club cards while flying, President Les noted that he had talked to Charlie Bauer, our AMA District VI Vice-President about our field. Les asked whether our club had any rights to the field. Mr. Bauer indicated that the Forest Preserve District holds all rights to the field and have merely given our club the ability to operate at the field. Les noted that we have no powers to enforce the rules other than to call the Forest Preserve Police if users of the field violate field rules.

Tim finished by presenting drafts of signs he intends to purchase for display on each of the entrances to the pit area. The signs indicate the requirement of all fliers to display AMA or club card while flying. The draft noted that reproductions would not be permitted, but after discussion with club members it was noted that reproductions were fine so long as the flier had the original with him while flying.

During the Planning Committee report, member George Shindler asked to be recognized by the club. George approached the front table and presented President Les with two gavels for Les to keep order during club meetings. The club thanks George for his fine workmanship in creating these gavels.

Tim finished his report by presenting the member information forms that he would like everyone to fill out and bring to the next meeting. Note that Tim has also emailed this form to members. This form was discussed at last meeting as a way of all of us to get to know other members and understand special skills our membership may have that can benefit club members.

Field Safety Committee: Co-Chairman Tim Novak indicated that he wants to stress keeping aircrafts from flying within the safety line at the field. He also noted that members should respect and stay out of the danger zone when starting or running up planes in the pit areas. The danger zone is directly in front of a spinning

propeller or directly on the sides. All propeller failures occur in this zone and accidents can be prevented by always stepping behind the motor to adjust and run-up. Tim also indicated that he wants to prevent children from being within the pit area as they can quickly be harmed or do harm to our planes.

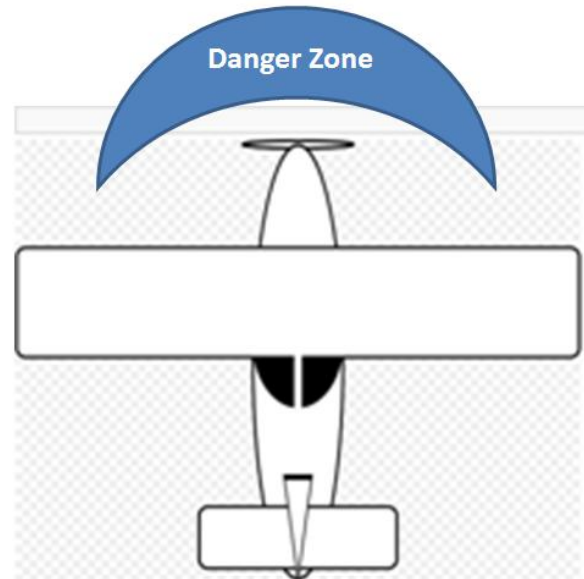

The club discussed sharing the flight space with helicopter pilots. With the help of Co-Chairman of the Safety Committee Rick Rivera, the club wants to make sure that fixed wing and helicopter pilots coexist safely.

Runway Committee: Chairman Les reported that he tried contacting the Forest Preserve personnel on the day of the meeting but was not able to do so. Last meeting we reported that the Forest Preserve District would be voting on a budget including our runway at the end of February. Let's all think happy thoughts that the runway project was approved.

**Now Available at Strictly RC**

Terry Gombert presented a really cool mini-helicopter on sale at Strictly RC for \$99. This double rotor style copter (yes, even a fixed wing guy could enjoy!) is normally \$119.99 and comes with 2.4GHz transmitter with a second battery available now for 50% off. See Strictly RC for this great deal.

### Strictly RC Fuel Purchase

The club was very happy to receive a bulk fuel purchase price list from Strictly RC. The price sheets were emailed to all members on the day after the meeting. Here is the prices per gallon that Jim has offered club members:

**BULK FUEL PRICES FOR 2011:**

***BULK ORDERS MUST BE IN BY MARCH 31***

WILDCAT 10% PREMIUM	\$13.50
WILDCAT 15% PREMIUM	\$13.89
WILDCAT 15% 2/4 STROKE	\$13.99
COOLPOWER 15%	\$14.99
COOLPOWER 15% 4-STROKE	\$14.99
COOLPOWER 30% HELI	\$23.89
COOLPOWER 20% PRO PATTERN	\$18.89
OMEGA 10%	\$13.00
OMEGA 15% 4-STROKE	\$14.99

Members may call Strictly RC at 708-456-9100 to place your order before March 31st, or drop by and order in person. These prices are only available on full case orders. The club thanks Jim for making these great prices available to our members, and of course for your continued support of our club. **Remember to place your order by March 31st!**

### Other New Business Discussions

The following matters were discussed:

- **Umbrellas:** The club discussed methods for keeping the umbrellas in working order. VP Mike noted that the umbrellas were attached to the tables and that when left open at the end of flying, windy weather breaks them. President Les asked about the supply of donated umbrellas by our new member last summer. These umbrellas are stored at the shed right now and will be used when the field is set up for the new season.
- **Donated Weed Whacker:** Member Tony Loquercio indicated that his neighbor was disposing of a weed whacker that needed some engine work. Tony turned it over to Jamie Solis who used his engine mechanics expertise to fix it. Tony and Jamie are donating the repaired whacker to the club. Thanks Tony and Jamie for this donation.

### Show and Tell/How To Discussion

First up for show and tell was President Les with his new E-Flight Piper Club in military colors.

Les noted that the plane only weighs 10 ounces and that it takes a two cell battery. Les noted that he has made some modifications to the wing joining mechanism. The stock E-Flight wing joining method employs magnets that Les was worried about failing in inverted flight. Les has updated it to more conventional means of wing attachment. He noted that he was very happy that with the struts attached, he found that the incidence of the wing was correct for the model and did not require any further adjustment. Great new model Les, if only the nice weather would get here so the little Cub can maiden in some gentle breezes.



**President Les opens the battery compartment of his E-Flight Piper Club.**

In what might be a club record for building project speed, member Mark Kwasinski, who only last month presented his Great Planes PT-40 kit project, this month showed off his new Goldberg Chipmunk kit project.

Mark noted that he had to make some modifications to the set up that Goldberg intended for the wing servos as he wanted to use a conventional servo in the center rather than two low profile servos. Mark heated and was

**Show and Tell/How To Discussion (cont'd)**

able to bend the plastic pushrod sleeves to enable the use of one servo connected to flexible push rods for each aileron.

Mark also related that he does not like to use CA glue as called for in most kits. Instead he uses regular wood glue which is lighter and easier to clean off hands. It also sands better than the rock hard globs of CA. Mark showed the cowl he purchased from Specialty Fiberglass for his new model. He also purchased the wheel pants and pointed out that he prefers the fiberglass parts over the ABS plastic that comes with most kits.

Finally Mark discussed his technique for bending balsawood for the top of the fuselage in the kit. Mark discussed using ammonia as a wetting agent for the balsa. He noted that when using ammonia, it can curdle the glue, so it is important to bend the balsa into shape, let dry and then glue. This time Mark used a steam pipe in his basement to provide some warmth to dry out the wood before gluing.

Mark has bolted a FX .61 to the Chipmunk for power, and intends to add a Pitts style muffler to maintain scale looks. Mark was searching for documentation examples of a Chipmunk that used a lot of Club yellow to minimize all the work of the conventional color scheme. Great job as usual Mark, can't wait to see that bird take flight.

**Next Meeting—Monday, April 4th at Strictly RC basement at 6 p.m.**

The next meeting will take place at our new club meeting time, 6:00 p.m. at the Strictly RC basement on Monday, April 4th.

By Ted Noncek, Secretary  
([tnoncek@comcast.net](mailto:tnoncek@comcast.net))



**Mark Kwasinski discusses using wood glue instead of CA in his Goldberg Chipmunk kit.**